

## CDH-Series Hopper Dryers

*The ultimate solution for non-hygroscopic resin drying*

The Comet CDH-Series hot air dryer dries plastic pellets directly at the machine. This system is perfect for TPE, SAN, PPS and all other non-hygroscopic resins. The CDH-Series is ideally suited for continuous drying from 5 to 400 pounds per hour of plastic granules.

Conventional drying hoppers have the hot air inlet located at the bottom of the hopper. However, in the CDH-Series, the hot air outlet is positioned at the top of the drying hopper. A stainless steel air tube with a diffuser runs through the center of the hopper. The radiant heat from this tube helps to preheat the material as it travels through the drying hopper. This process, along with cyclonic exhaust air, dramatically improves the quality of the drying compared to other hopper designs.

### Standard Features

- Fully stainless steel internal parts.
- Hopper lid provides easy mounting of hopper loader.
- Electrical circuit built to comply with NFPA 79 safety requirements.
- Adjustable overheat safety thermostat.
- Clean-out door with inspection glass standard on CDH models 100-1,300 lbs.
- 7-day timer clock for auto startup.
- Temperature controller with digital display and P.I.D. loop.
- Sight glass in the hopper allows for visual inspection of the drying resin.
- Connect any number of CDH hoppers to a Honeycomb Matrix Dryer for precise, reliable dehumidified drying.

### Options

- Hopper base assembly with drawer magnet.
- Shutoff slide valve.
- Drying up to 200°C (390°F).
- Mobile floor stand.
- Dust filter for exhaust air.



## CDH-Series Hopper Dryers

The ultimate solution for non-hygroscopic resin drying

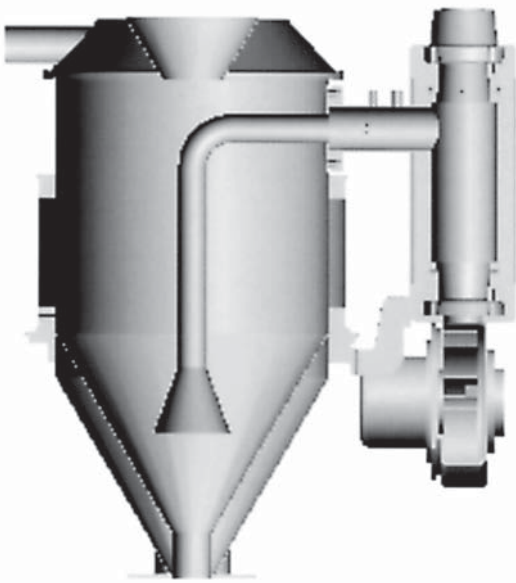

Unique Drying Design

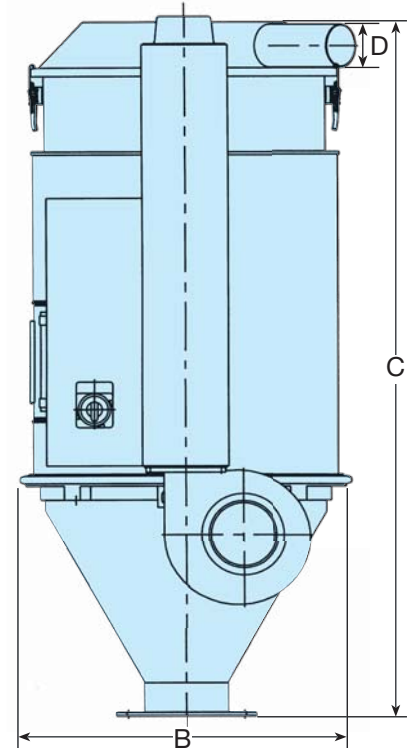
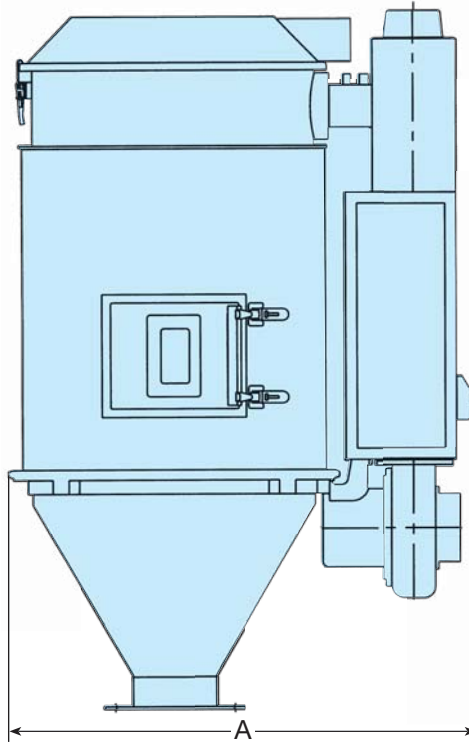

### Specifications

Hopper Capacity	<i>pounds</i>	33	66	110	165	220	330	440	660	880	1320	
Hopper Capacity	<i>liter</i>	25	50	85	115	170	230	335	460	670	1000	
Hopper Capacity	<i>kg</i>	15	30	50	75	100	150	200	300	400	600	
Blower Motor	<i>W</i>	50	80	100	100	100	100	200	200	400	400	
Heating Capacity	<i>kW</i>	1.6	2.7	4.0	5.0	6.0	8.0	10.0	15.0	20.0	20.0	
Drying Temp. Range		275° F or 150° C (390°F or 200° C as an option)										
7-Day Timer Clock		Standard					Standard					
Hopper Cleaning Door		N/A			Standard							
Voltage (3-phase)	<i>V</i>	208 ~ 460										
Width (A)	<i>mm</i>	590	665	755	755	835	835	970	970	1300	1300	
Depth (B)	<i>mm</i>	420	455	510	510	590	590	710	710	1000	1000	
Height (C)	<i>mm</i>	635	820	940	1180	1240	1566	1550	1970	1710	2260	
Outlet Port (D)	<i>in</i>	1.5	2	2	2	2.5	2.5	3	3	4	4	
Weight (approx.)	<i>kg</i>	30	45	60	80	100	140	165	195	230	280	



# COMET

PLASTIC EQUIPMENT, LLC

378 Northlake Blvd. - Unit 261  
N. Palm Beach FL 33408

**TOLL FREE: 1-800-328-5088**

Fax: 937-937-296-9039

[www.cometpe.com](http://www.cometpe.com)

**REPRESENTED BY:**